

M 43 C

Low Emission Engine

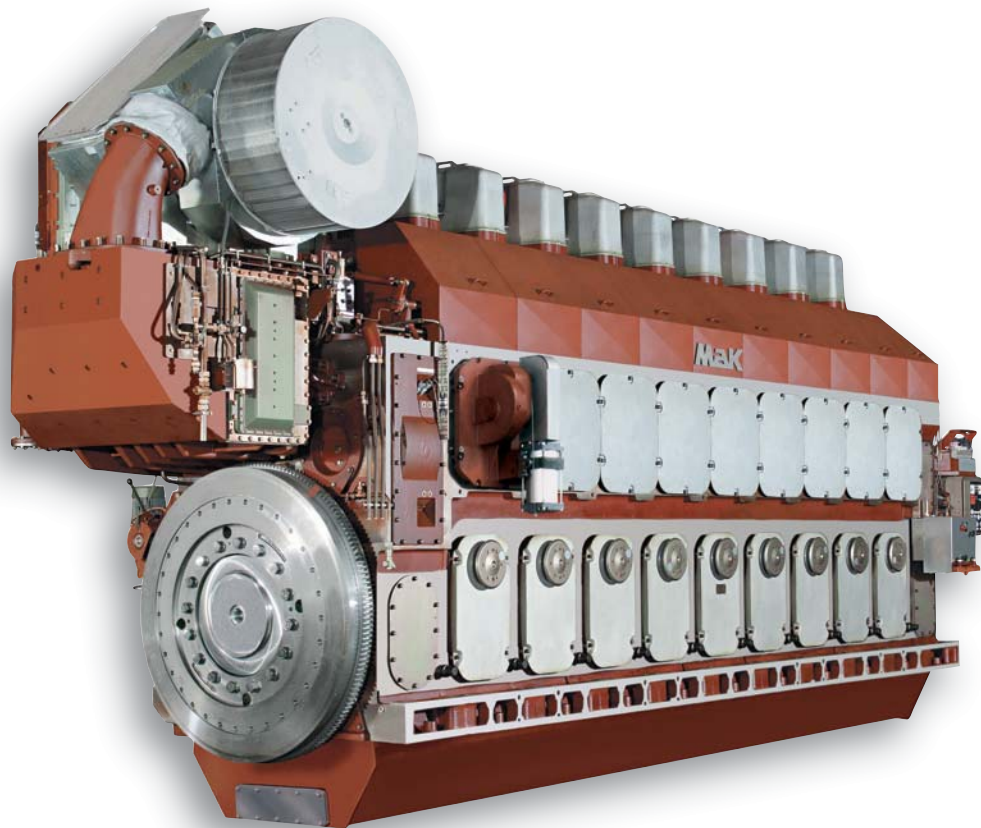

MaK

CATERPILLAR®



M 43 C ► Low Emission Engine

IMO II in sight – First MaK

Low Emission Engine already in operation

Back in 2000, Caterpillar Motoren identified three emission levels for the MaK marine product in order to cope with short to midterm emission regulations. These were a base line IMO engine, which fulfils MARPOL 73/78, Annex VI, an IMO-compliant engine with invisible smoke emissions and a Low Emission Engine (LEE) which meets the expected NO_x emission range of IMO II and is also invisible in smoke. In addition, this strategy favours inside-the-engine means because of their clear advantage with respect to cost, complexity and maintenance.

■ LEE for low NO_x

The key issue for low NO_x emissions is to increase the compression ratio of the base engine. Ten years ago, a compression ratio of 11–12 was standard, for IMO I the ratio was raised to 14–15 and for IMO II ratios of 17 will be needed. Another cornerstone of the MaK LEE concept is the Miller Cycle, i. e. modification of the engine's valve timing to achieve cooler

combustion. For IMO I only a small Miller effect of 5% was utilised, however, IMO II requires a Miller effect of 20%. This is a big challenge for the turbo charger, which has to provide boost ratios of 5 in order to maintain today's Mean Effective Pressure (BMEP) values.

By combining increased compression ratio and the Miller effect, NO_x emissions can be reduced by around 30% without sacrificing engine efficiency (BSFC). However, such a simple LEE engine would suffer from poor load pick-up at idle and visible soot emissions at part load. Because of this, the MaK LEE concept uses a "flexible camshaft" to enable both low NO_x emissions, excellent load pick up and invisible soot at all loads.

■ A win-win situation for operators and the environment

All existing MaK M 20 C, M 25 C, M 32 C and M 43 C series marine engines afloat can be converted to MaK LEE. Building upon

proven technology residing inside the engine, MaK LEE bears many advantages for vessel owners and operators.

MaK LEE today already provides a power plant complying with expected future IMO emission regulations. This allows shipping companies to increase their reputation for environmental-friendly marine business operations. In addition, the emission levels achieved with MaK LEE enable shipping companies to obtain so-called environmental classes with Marine Classification Societies, such as DNV Clean Design, GL Green Passport, LR Character N or the German Government's Blauer Engel. These environmental classes not only add to the vessel owner's image but also reduce harbour fees in some parts of the world.

■ As from 1. 1. 2011 IMO II will become effective

Already today Caterpillar is well prepared to meet these technological requirements. We are currently successfully testing engines that meet IMO II emission requirements. The following components have been changed:

- Turbocharging system
- injection system
- combustion chambers
- camshaft
- FCT system

The FCT system is the major building block of the LEE engine concept. The pilot engines were introduced into the market in 2007.

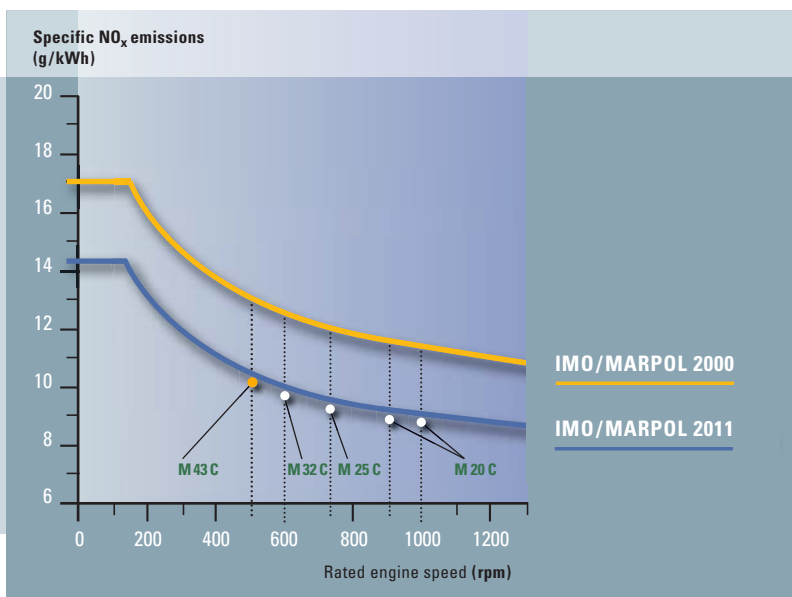

M 43 C ► FCT

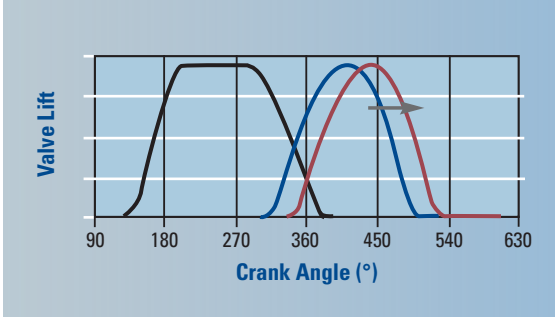

Flex Cam Technology FCT (schematic diagram)

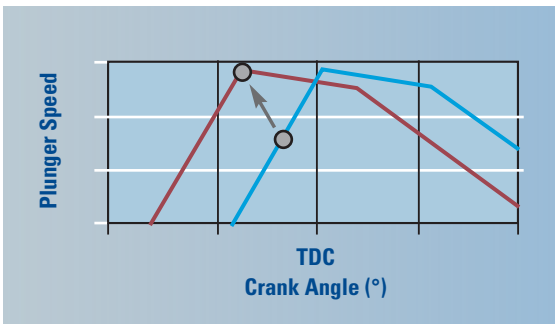

Flex Cam Technology

Building upon the Emission Reduction System integration concept, FCT achieves synergy between flexible fuel systems and advanced air systems with maximum utilization of the current engine design. While maintaining high fuel injection pressure over the whole operating range, fuel injection and inlet valve timing are load controlled and influenced by a lever shaft which affects injection timing/pressure and inlet valve events. Valve timing changes at part load to raise effective compression and enhance complete combustion. In addition, shifting the relative position of the lever to the fuel cam increases injection pressure, producing a finer atomization of fuel in a load range where it would otherwise be difficult to control smoke.



Customer value sequence and benefits

Flex Cam Technology (FCT)

- High potential for NO_x and smoke reduction.
- Hardware changes to prepare for IMO II – sustainable investment.
- Low complexity
- Technically lower risk – application of existing technology.

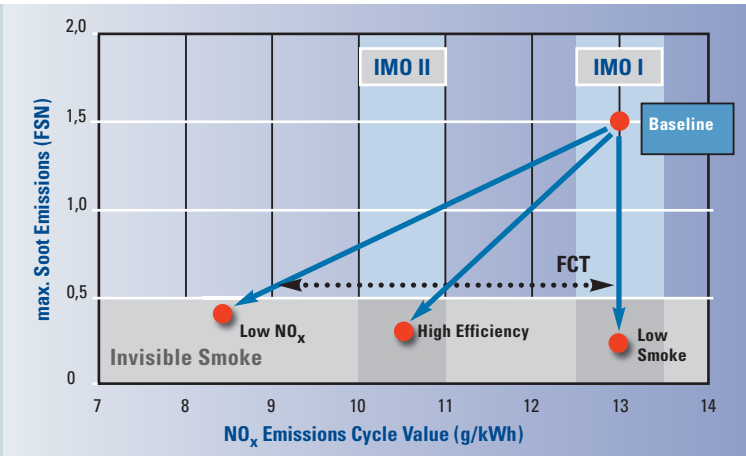

schematic diagram

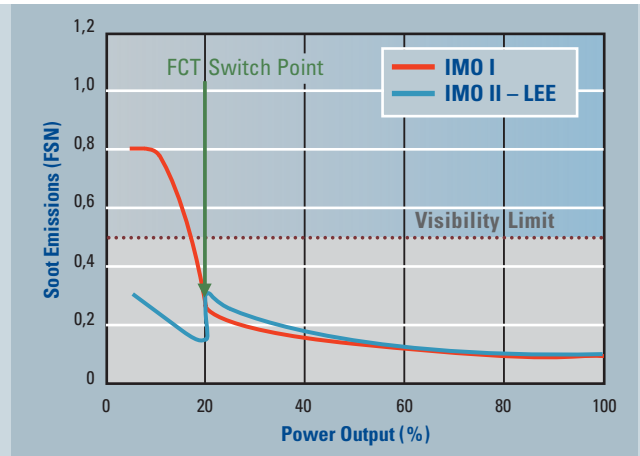



M 43 C – Low Emission Engine ▶ Engine Description (Preliminary)

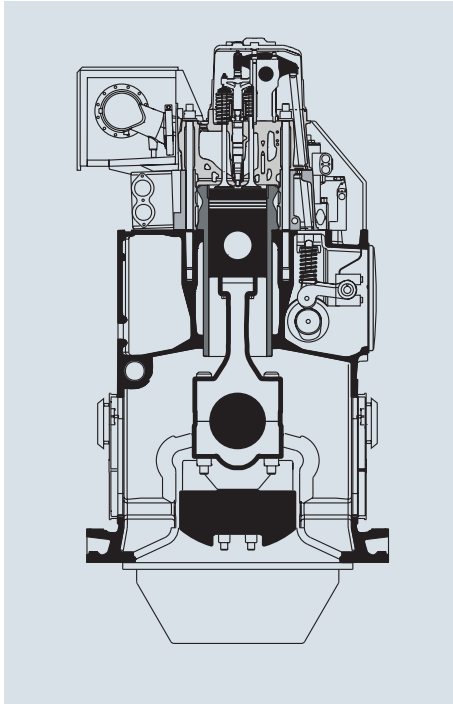

Engine	Output range		Speed rpm	Mean eff. pressure bar	Mean piston speed m/s	Bore mm	Stroke mm	Spec. fuel consumption	
	kW	mhp						100%	85%
6 M 43 C	5400	7340	500	24.4	10.2	430	610	176	175
	5400	7340	514	23.7	10.5	430	610	176	175
	6000	8160	500	27.1	10.2	430	610	177	176
	6000	8160	514	26.4	10.5	430	610	178	177
7 M 43 C	6300	8570	500	24.4	10.2	430	610	177	176
	6300	8570	514	23.7	10.5	430	610	177	176
	7000	9520	500	27.1	10.2	430	610	178	177
	7000	9520	514	26.4	10.5	430	610	179	178
8 M 43 C	7200	9790	500	24.4	10.2	430	610	176	175
	7200	9790	514	23.7	10.5	430	610	176	175
	8000	10880	500	27.1	10.2	430	610	177	176
	8000	10880	514	26.4	10.5	430	610	178	177
9 M 43 C	8100	11020	500	24.4	10.2	430	610	176	175
	8100	11020	514	23.7	10.5	430	610	176	175
	9000	12240	500	27.1	10.2	430	610	177	176
	9000	12240	514	26.4	10.5	430	610	178	177

Swept volume: 88.6 l/cyl.
 Output/cyl.: 900/1000 kW
 BMEP: 24.4/23.7/27.1/26.4 bar
 Revolutions: 500/514 rpm
 Turbocharging: single log
 Direction of rotation: clockwise, option: counter-clockwise

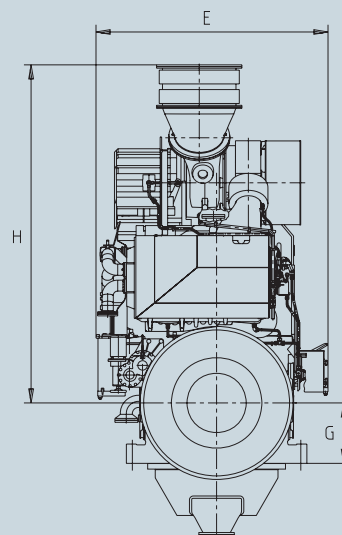
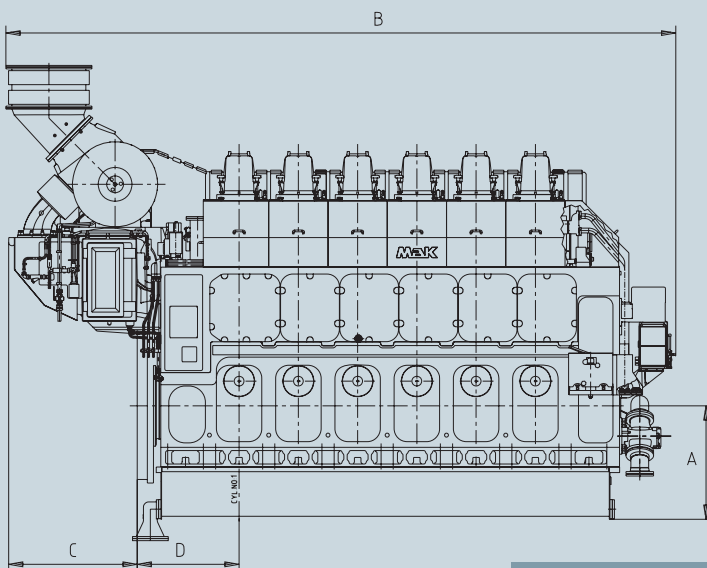

Dimensions (mm) and Weights (t)

Engine	A	B	C	D	E	G	H	t
6 M 43 C	1396	8251	1583	1255	2878	750	4194	93.0
7 M 43 C	1396	8981	1583	1255	2878	750	4194	106.0
8 M 43 C	1396	9798	1583	1255	2878	750	4749	114.0
9 M 43 C	1396	10528	1583	1255	2878	750	4749	126.0

Engine centre distance: 3,400 mm

Removal of cylinder liner:
 in transverse direction 4165 mm
 in longitudinal direction 4610 mm

Nozzle position: ask for availability

This engine is only available with dry oil sump

Engine with turbocharger at free end available, ask for dimensions

M 43 C – Low Emission Engine ▶ Technical Data (Preliminary)

	Cylinder	6	7	8	9
Performance data					
Maximum continuous rating acc. ISO 3046/1	kW	6000	7000	8000	9000
Speed	1/min	500/514	500/514	500/514	500/514
Minimum speed	1/min	300	300	300	300
Brake mean effective pressure	bar	27.1	27.1	27.1	27.1
Charge air pressure	bar	4	4	4	4
Firing pressure	bar	210	210	210	210
Combustion air demand (ta = 20 °C)	m³/h	35000	40850	46700	52250
Specific fuel oil consumption					
n = const ¹⁾ 100 %	g/kWh	177	177	177	177
85 %	g/kWh	177	177	177	177
75 %	g/kWh	-/179	-/179	-/179	-/179
50 %	g/kWh	-/185	-/185	-/185	-/185
Lubricating oil consumption ²⁾	g/kWh	0.6	0.6	0.6	0.6
NO _x emission ³⁾	g/kWh	10	10	10	10
Turbocharger type		ABB A165	ABB A170	ABB A170	ABB A170
Fuel					
Engine driven booster pump	m³/h	-/-	-/-	-/-	-/-
Stand-by booster pump	m³/h	4.2/10	4.9/10	5.6/10	6.3/10
Mesh size MDO fine filter	mm	0.025	0.025	0.025	0.025
Mesh size HFO automatic filter	mm	0.010	0.010	0.010	0.010
Mesh size HFO fine filter	mm	0.034	0.034	0.034	0.034
Nozzle cooling by lubricating oil system					
Lubricating Oil					
Engine driven pump	m³/h/bar	146/10	146/10	203/10	203/10
Independent pump	m³/h/bar	120/10	140/10	160/10	180/10
Working pressure on engine inlet	bar	4 - 5	4 - 5	4 - 5	4 - 5
Engine driven suction pump	m³/h/bar	-/-	-/-	-/-	-/-
Independent suction pump	m³/h/bar	175/3	175/3	240/3	240/3
Priming pump pressure/suck pump	m³/h/bar	16/5	16/5	20/5	20/5
Sump tank content/dry sump content	m³	8.4	9.8	11.2	12.6
Temperature at engine inlet	°C	60 - 65	60 - 65	60 - 65	60 - 65
Temperature controller NB	mm	125	125	150	150
Double filter NB	mm	150	150	150	150
Mesh size double filter	mm	0.08	0.08	0.08	0.08
Mesh size automatic filter	mm	0.03	0.03	0.03	0.03

6



	Cylinder	6	7	8	9
Fresh water cooling					
Engine content	m ³	0.6	0.7	0.8	0.9
Pressure at engine inlet min/max	bar	2.5/6.0	2.5/6.0	2.5/6.0	2.5/6.0
Header tank capacity	m ³	0.6	0.6	0.6	0.6
Temperature at engine outlet	°C	80 - 90	80 - 90	80 - 90	80 - 90
Two circuit system					
Engine driven pump HT	m ³ /h/bar	-/-	-/-	-/-	-/-
Independent pump HT	m ³ /h/bar	100/4.5	110/4.6	120/4.6	130/4.5
HT-Controller NB	mm	125	125	150	150
Water demand LT-charge air cooler	m ³ /h	80	100	100	100
Temperature at LT-charge air cooler inlet	°C	38	38	38	38
Heat Dissipation					
Specific jacket water heat	kJ/kW	500	500	500	500
Specific lub oil heat	kJ/kW	490	490	490	490
Lub oil cooler	kW	820	960	1090	1225
Jacket water	kW	835	975	1115	1250
Charge air cooler (HT-Stage) ⁴⁾	kW	2436	2811	3213	3564
Charge air cooler (LT-Stage) ⁴⁾ (HT-Stage before engine)	kW	470	570	648	772
Heat radiation engine	kW	260	300	330	390
Exhaust					
Silencer/spark arrester NB	mm	900	900	1000	1000
Pipe diameter NB after turbine	mm	900	900	1000	1000
Exhaust gas temperature after turbine (intake air 25°C) ⁵⁾	°C	300	305	305	310
Exhaust gas mass flow (intake air 25°C) ⁵⁾	kg/h	43260	50490	57720	64580
Maximum exhaust gas pressure drop	bar	0.03	0.03	0.03	0.03
Starting air					
Starting air pressure max.	bar	30	30	30	30
Minimum starting air pressure	bar	14	14	14	14
Air consumption per start ⁶⁾	Nm ³	2.4	2.4	3	3

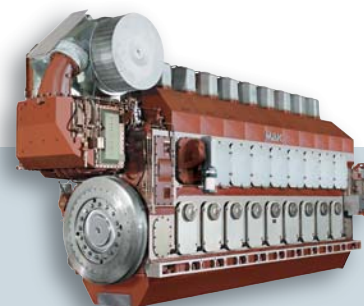

- 1) Reference conditions: LCV = 42700 kJ/kg, ambient temperature 25 °C
charge air coolant temperature 25 °C, tolerance 5 %, + 1 % for engine driven pump
- 2) Standard value based on rated output, tolerance ± 0.3 g/kWh
- 3) MARPOL 73/78, annex VI, cycle E2, D2
- 4) Charge air heat based on 45 °C ambient temperature
- 5) Tolerance 10 %, rel. humidity 60 %
- 6) Preheated engine

M 43 C – Low Emission Engine ▶ Heat Balance (Preliminary)

■ 6 M43C

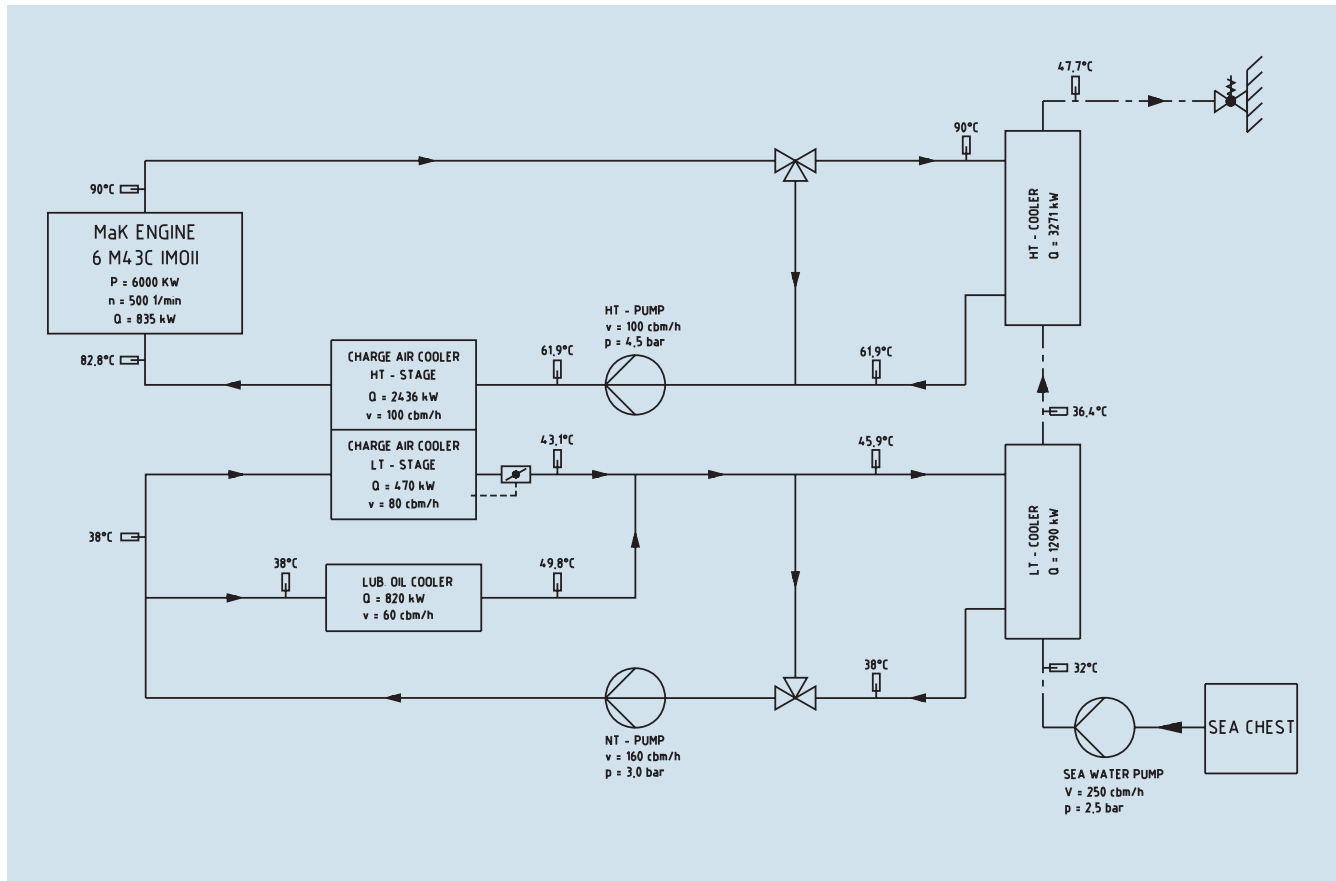

■ 7 M43C

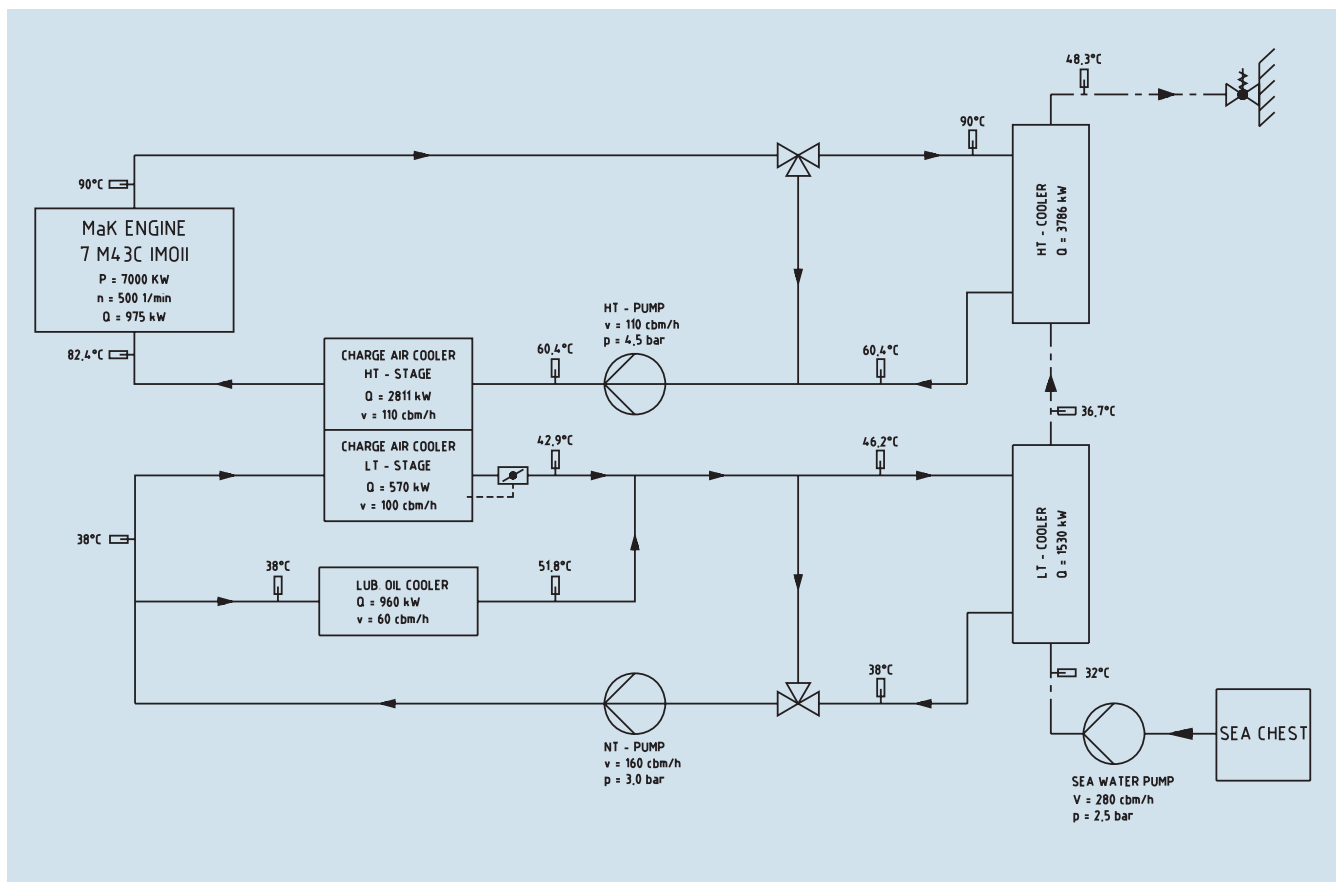

■ 8 M43C

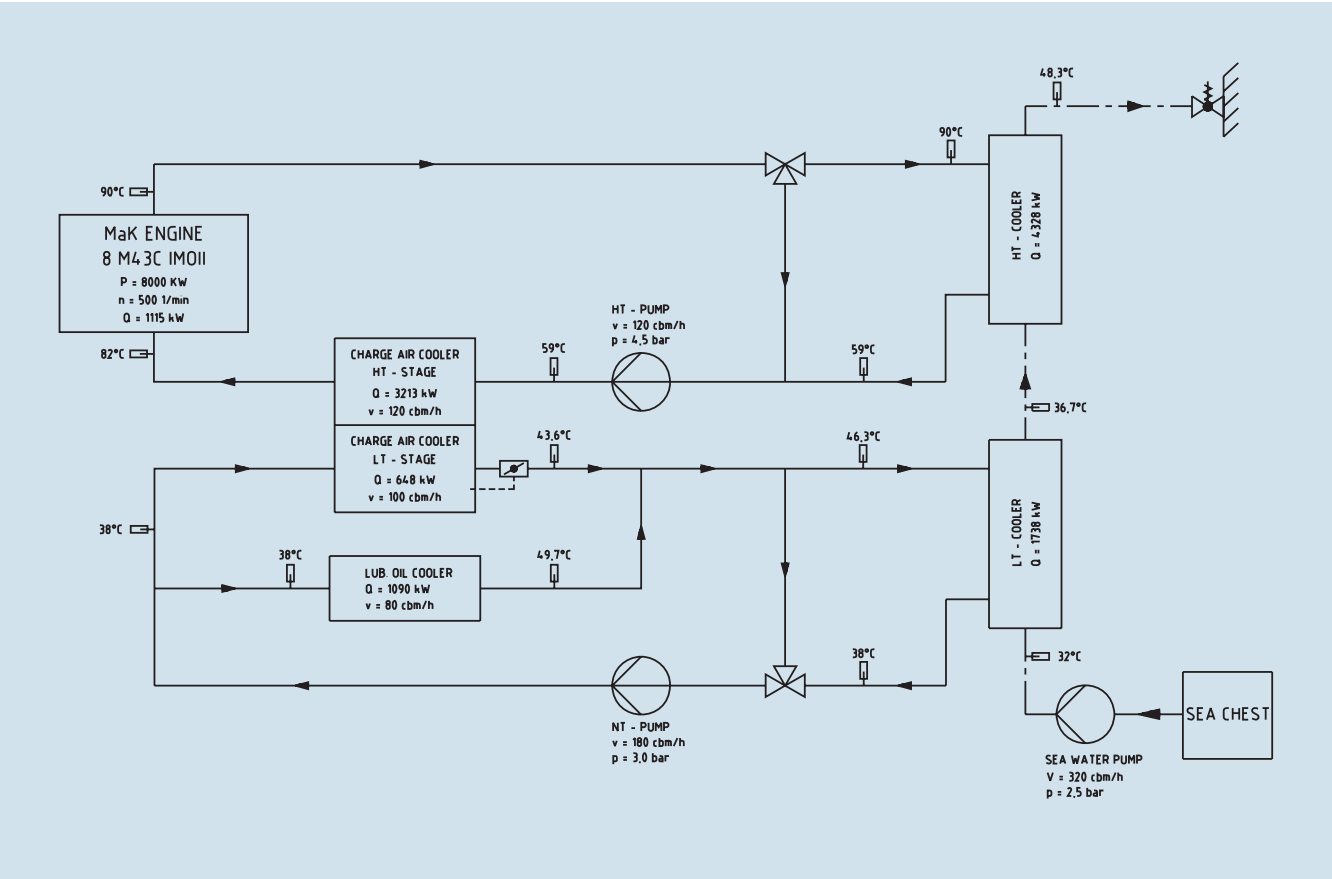

■ 9 M43C

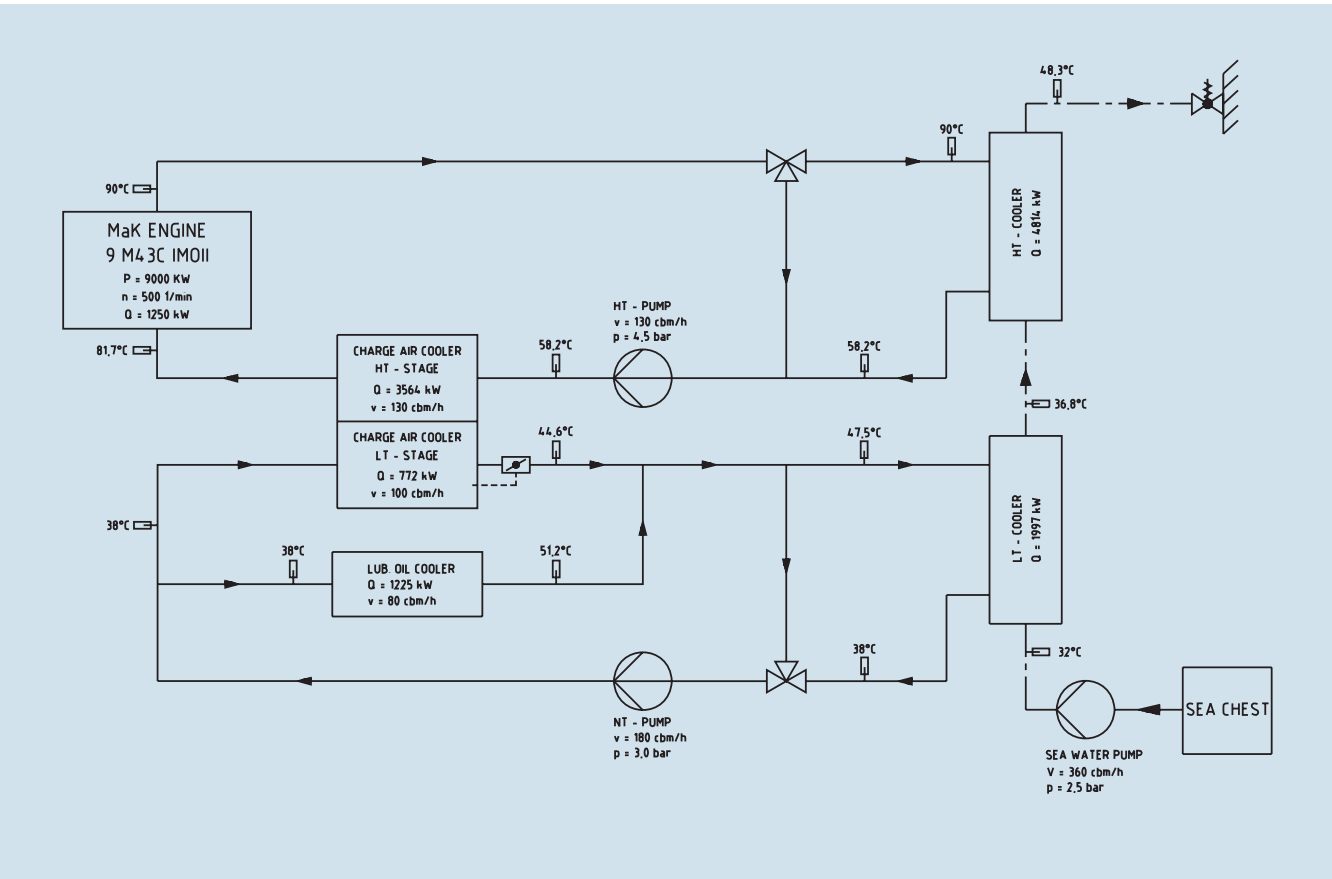

One Strong Line of World-Class Diesel Engines Perfect Solutions for Main Propulsion and On-Board Power Supply

The Program: Quality is our Motto

For more than 80 years we have developed, built, supplied and serviced diesel engines – worldwide. Today Caterpillar Marine with its brands Cat and MaK offer high-speed and medium-speed engines with power ratings from 11 kW to 16,000 kW. Many different engine families are available to meet your specific application needs.

Cat and MaK diesel engines are distinguished by high reliability, extremely low operational costs, simple installation and maintenance and compliance with IMO environmental regulations.

The application of engines in main and auxiliary marine power systems varies greatly and extends from high-speed boats and yachts, through tugs, trawlers and offshore vessels to freighters, ferries and cruise liners.

Caterpillar Marine Power Systems Sales and Service Organization

Caterpillar has combined the sales and service activities and responsibility of their Cat and MaK brand marine engine business into Caterpillar Marine Power Systems with headquarters in Hamburg/Germany.

In setting-up this worldwide structure, we have concentrated on integrating the Cat and MaK brand groups into a single, united marine team, which utilises the particular expertise of each group.

Commercial marine engine business is split into three geographic regions,
– Europe, Africa, Middle East
– Americas
– Asia-Pacific,



■ Medium-Speed Engines



● **M 20 C**
6, 8, 9 cylinder
1,020–1,710 kW



● **M 25 C**
6, 8, 9 cylinder
1,800–3,000 kW



● **M 32 C**
6, 8, 9 cylinder
2,880–4,500 kW

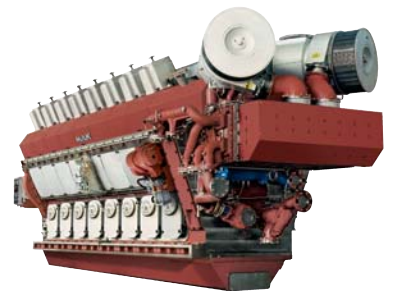

● **VM 32 C**
12, 16 cylinder
5,760–8,000 kW

10



Main Propulsion Engines

Caterpillar Marine Power Systems Production Facilities

which manage all sales and product support activities. They have direct responsibility for achieving the ambitious growth targets set for the Cat and MaK brands and for providing our customers and dealers with complete marine solutions.

Caterpillar's global dealer network provides a key competitive edge – customers deal with people they know and trust.

Cat dealers strive to form a strong working relationship with their customers, offering comprehensive and competent advice from project support to repair work.

Some of the most advanced manufacturing concepts are used at Caterpillar locations throughout the world to produce engines in which reliability, economy and performance are second-to-none.

From the production of core components to the assembly of complete engines, quality is always the top priority.

Comprehensive, recognized analysis systems, test procedures and measuring methods ensure that quality requirements are met throughout all the individual manufacturing phases. All of our production facilities are certified under 1:2000 ISO 9001 EN, the international benchmark that is helping to set new quality standards worldwide.

In addition to product quality, our customers expect comprehensive service which includes the supply of spare parts throughout the life of the engine.

Caterpillar Logistics Services, Inc., located in Morton, Illinois, is the largest parts distribution facility within the Cat Logistics network and is also the headquarters for all the worldwide distribution centres. Morton utilises sophisticated material handling, storage and retrieval systems to support Caterpillar's customer service goals.

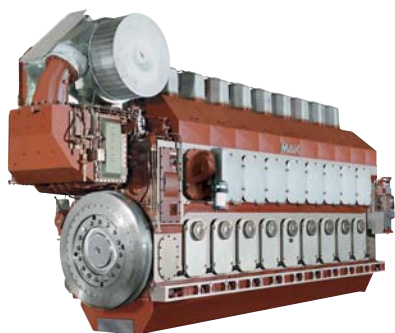

● **M 43 C**
6, 7, 8, 9 cylinder
5,400–9,000 kW

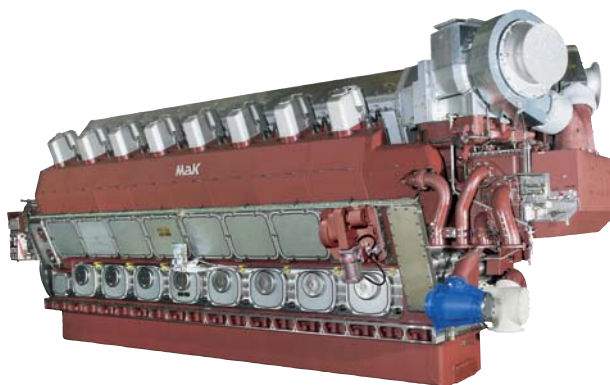

● **VM 43 C**
12, 16 cylinder
10,800–16,000 kW

► MaK LEE will soon be part of all MaK engines!

Caterpillar Marine Power Systems

Headquarters

Caterpillar Marine Power Systems
Neumühlen 9
22763 Hamburg/Germany

Phone: +49 40 2380-3000
Telefax: +49 40 2380-3535

Europe, Africa, Middle East

Caterpillar Marine Power Systems
Neumühlen 9
22763 Hamburg/Germany

Phone: +49 40 2380-3000
Telefax: +49 40 2380-3535

Americas

MaK Americas Inc.
3450 Executive Way
Miramar Park of Commerce
Miramar, FL 33025/USA
Phone: +1 954 885 3200
Telefax: +1 954 885 3131

Asia Pacific

Caterpillar Marine Trading (Shanghai) Co., Ltd.
25/F, Caterpillar Marine Center
1319, Yan'an West Road
200050 Shanghai/P. R. China
Phone: +86 21 6226 2200
Telefax: +86 21 6226 4500

Caterpillar Marine Asia Pacific Pte Ltd
14 Tractor Road
Singapore 627973/
Singapore
Phone: +65 68287-600
Telefax: +65 68287-624

For more information please visit our website:
MARINE.CAT.COM

Subject to change without notice.
Leaflet No. 248 · 09.09 · e · L+S · VM3

© 2009 Caterpillar All Rights Reserved. Printed in Germany. CAT, CATERPILLAR, their respective logos, ACERT, ADEM, „Caterpillar Yellow“ and the POWER EDGE trade dress, as well as corporate identity used herein, are trademarks of Caterpillar and may not be used without permission



Caterpillar Marine Power Systems is committed to sustainability. This document is printed on PEFC certificated paper.

