

VM 43 C

Low Emission Engine

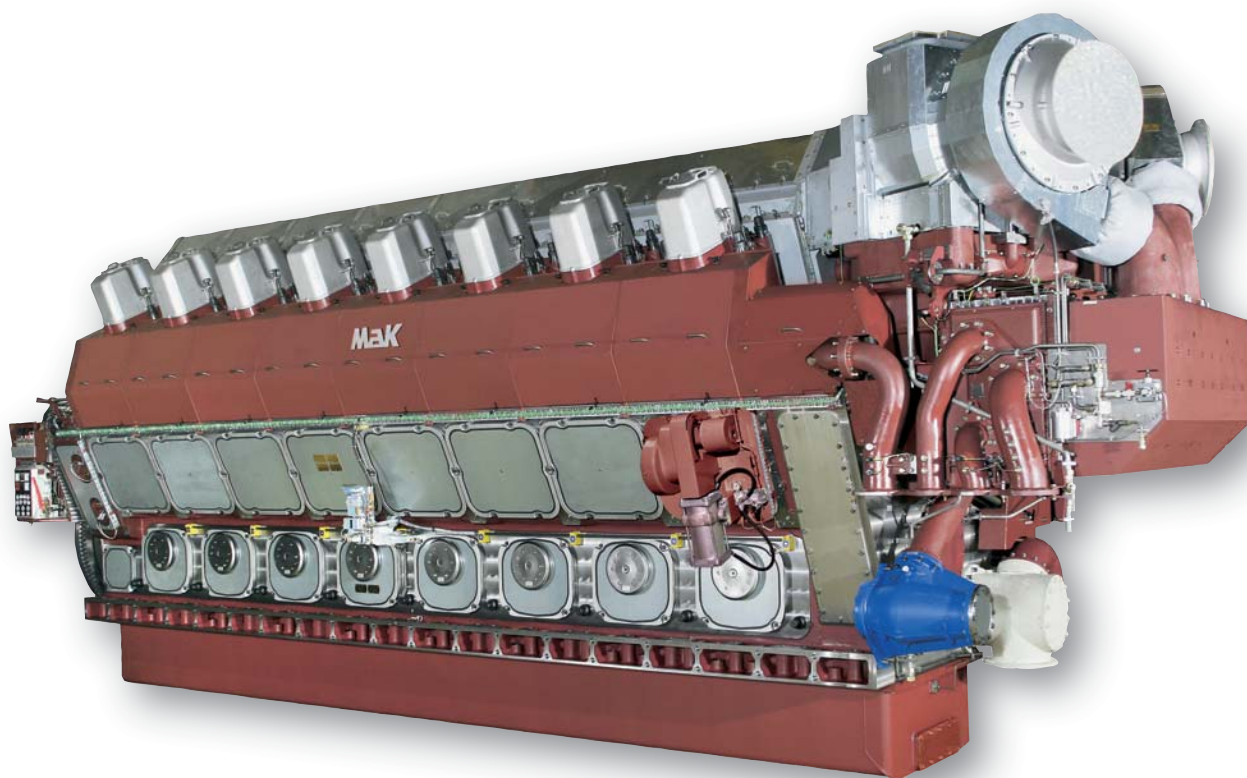

MaK

CATERPILLAR®



VM 43 C ► Low Emission Engine

IMO II in sight – First MaK

Low Emission Engine already in operation

Back in 2000, Caterpillar Motoren identified three emission levels for the MaK marine product in order to cope with short to midterm emission regulations. These were a base line IMO engine, which fulfils MARPOL 73/78, Annex VI, an IMO-compliant engine with invisible smoke emissions and a Low Emission Engine (LEE) which meets the expected NO_x emission range of IMO II and is also invisible in smoke. In addition, this strategy favours inside-the-engine means because of their clear advantage with respect to cost, complexity and maintenance.

■ LEE for low NO_x

The key issue for low NO_x emissions is to increase the compression ratio of the base engine. Ten years ago, a compression ratio of 11–12 was standard, for IMO I the ratio was raised to 14–15 and for IMO II ratios of 17 will be needed. Another cornerstone of the MaK LEE concept is the Miller Cycle, i. e. modification of the engine's valve timing to achieve cooler

combustion. For IMO I only a small Miller effect of 5% was utilised, however, IMO II requires a Miller effect of 20%. This is a big challenge for the turbo charger, which has to provide boost ratios of 5 in order to maintain today's Mean Effective Pressure (BMEP) values.

By combining increased compression ratio and the Miller effect, NO_x emissions can be reduced by around 30% without sacrificing engine efficiency (BSFC). However, such a simple LEE engine would suffer from poor load pick-up at idle and visible soot emissions at part load. Because of this, the MaK LEE concept uses a "flexible camshaft" to enable both low NO_x emissions, excellent load pick up and invisible soot at all loads.

■ A win-win situation for operators and the environment

All existing MaK M 20 C, M 25 C, M 32 C and M 43 C series marine engines afloat can be converted to MaK LEE. Building upon

proven technology residing inside the engine, MaK LEE bears many advantages for vessel owners and operators.

MaK LEE today already provides a power plant complying with expected future IMO emission regulations. This allows shipping companies to increase their reputation for environmental-friendly marine business operations. In addition, the emission levels achieved with MaK LEE enable shipping companies to obtain so-called environmental classes with Marine Classification Societies, such as DNV Clean Design, GL Green Passport, LR Character N or the German Government's Blauer Engel. These environmental classes not only add to the vessel owner's image but also reduce harbour fees in some parts of the world.

■ As from 1. 1. 2011 IMO II will become effective

Already today Caterpillar is well prepared to meet these technological requirements. We are currently successfully testing engines that meet IMO II emission requirements. The following components have been changed:

- Turbocharging system
- injection system
- combustion chambers
- camshaft
- FCT system

The FCT system is the major building block of the LEE engine concept. The pilot engines will be introduced into the market in 2008.

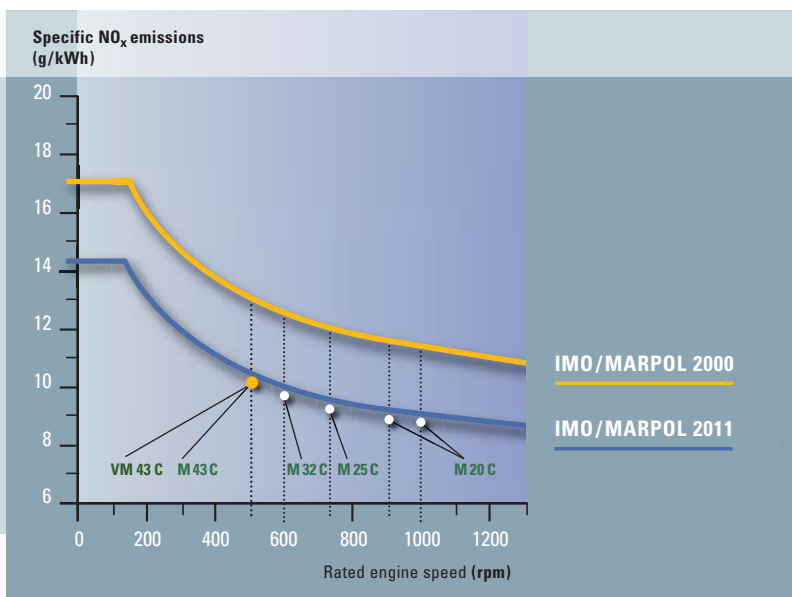

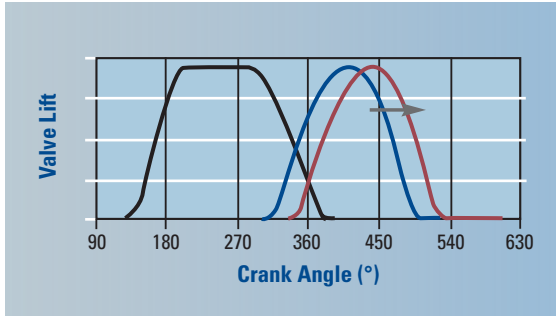

Flex Cam Technology FCT (schematic diagram)

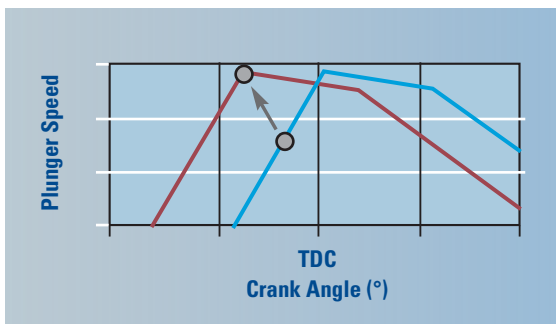

Flex Cam Technology

Building upon the Emission Reduction System integration concept, FCT achieves synergy between flexible fuel systems and advanced air systems with maximum utilization of the current engine design. While maintaining high fuel injection pressure over the whole operating range, fuel injection and inlet valve timing are load controlled and influenced by a lever shaft which affects injection timing/pressure and inlet valve events. Valve timing changes at part load to raise effective compression and enhance complete combustion. In addition, shifting the relative position of the lever to the fuel cam increases injection pressure, producing a finer atomization of fuel in a load range where it would otherwise be difficult to control smoke.



Customer value sequence and benefits

Flex Cam Technology (FCT)

- High potential for NO_x and smoke reduction.
- Hardware changes to prepare for IMO II – sustainable investment.
- Low complexity
- Technically lower risk – application of existing technology.

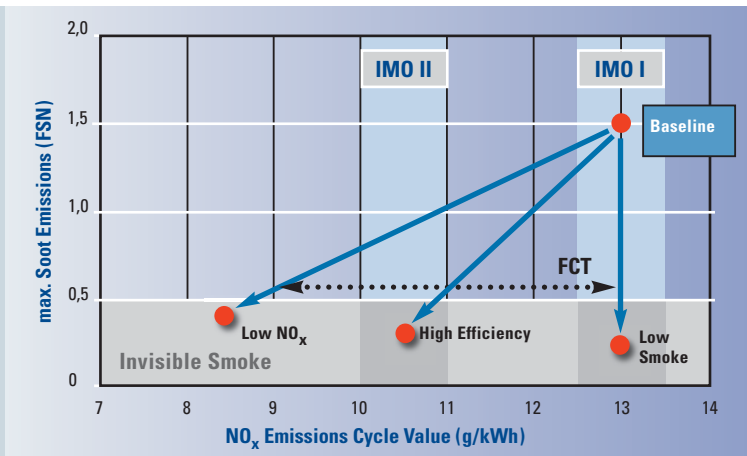

schematic diagram

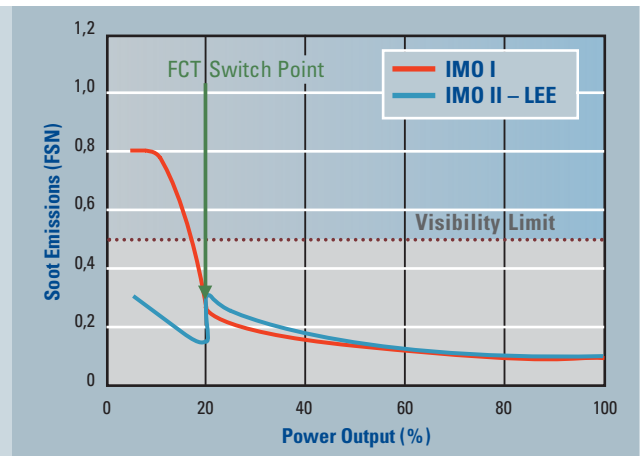

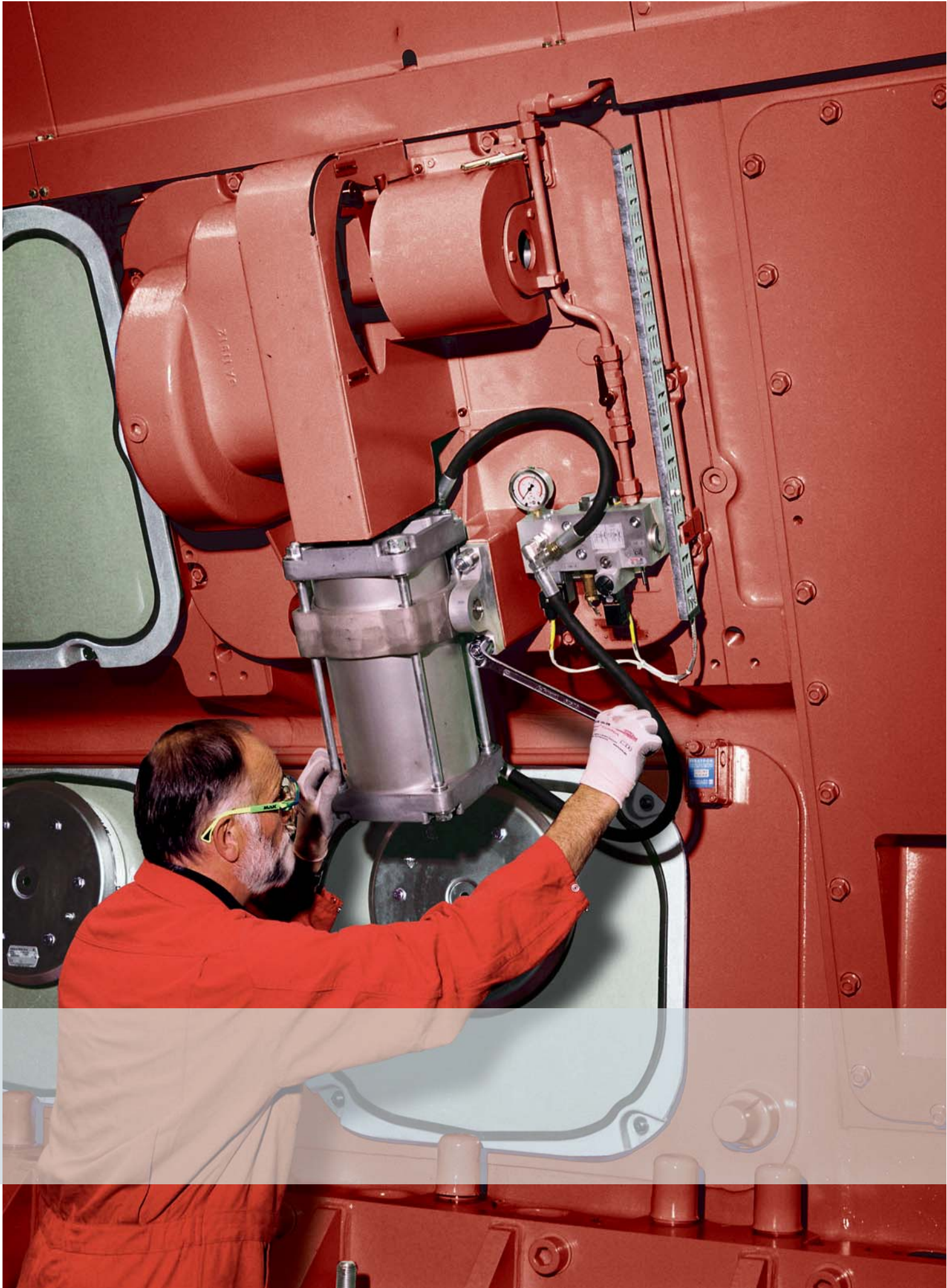

VM 43 C – Low Emission Engine ▶ Engine Description (Preliminary)

	Output range		Speed	Mean eff. pressure	Mean piston speed	Bore	Stroke	Spec. fuel consumption	
	kW	mph						100 %	85 %
			rpm	bar	m/s	mm	mm	g/kWh	g/kWh
12 M 43 C	10800	14690	500	24.4	10.2	430	610	176	175
	10800	14690	514	23.7	10.5	430	610	176	175
	12000	16320	500	27.1	10.2	430	610	177	176
	12000	16320	514	26.4	10.5	430	610	178	177
16 M 43 C	14400	19580	500	24.4	10.2	430	610	176	175
	14400	19580	514	23.7	10.5	430	610	176	175
	16000	21760	500	27.1	10.2	430	610	177	176
	16000	21760	514	26.4	10.5	430	610	178	177

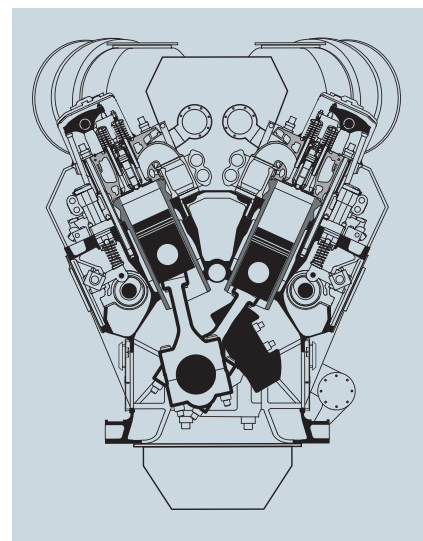

Specific lubricating oil consumption 0.6 g/kWh, ± 0.3 g/kWh
LCV = 42700 kJ/kg, without engine-driven pumps, tolerance 5%

Swept volume: 88.6 l/cyl.
Output/cyl.: 1000 kW
BMEP: 27.1 bar/26.4 bar
Revolutions: 500/514 rpm
Turbocharging: single log
Direction of rotation: clockwise, option: counter-clockwise

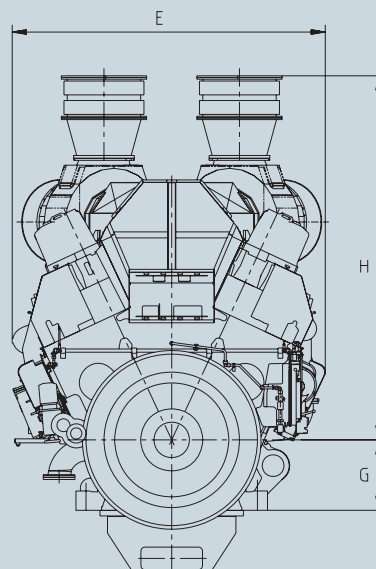
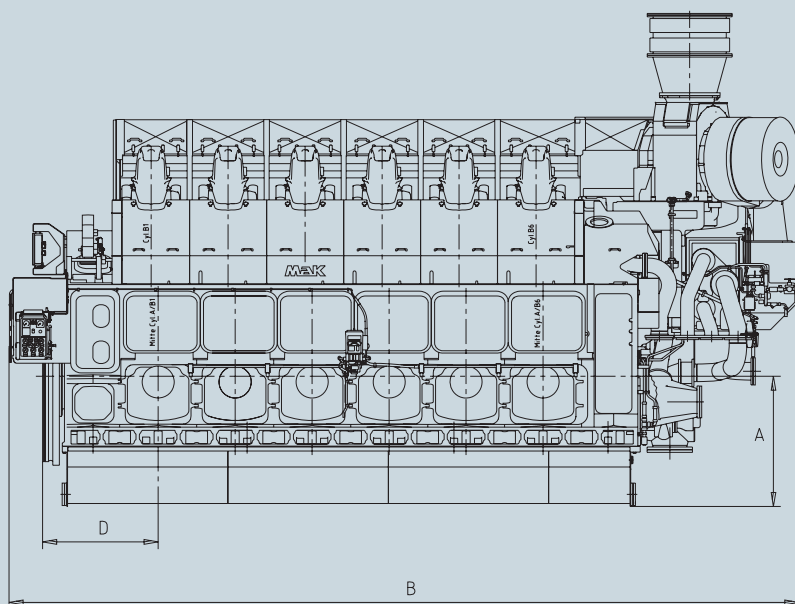

Dimensions (mm) and Weights (t)

Type	A	B	D	E	G	H	t
12 M 43 C	1625	9847	1440	3890	875	4524	162.0
16 M 43 C	1625	11943	1440	4027	875	4524	215.0

Engine centre distance: 4500 mm
Removal of cylinder liner:
in transverse direction 3700 mm
Nozzle position: ask for availability

This engine is only available with dry oil sump
Engine with turbocharger at flywheel end available,
ask for dimensions

VM 43 C – Low Emission Engine ► Technical Data (Preliminary)

	Cylinder	12	16
Performance data			
Maximum continuous rating acc. ISO 3046/1	kW	12000	16000
Speed	1/min	500/514	500/514
Minimum speed	1/min	300	300
Brake mean effective pressure	bar	27.1/26.4	27.1/26.4
Charge air pressure	bar	4.0	4.0
Firing pressure	bar	210	210
Combustion air demand (ta = 20 °C)	m ³ /h	70000	86700
Specific fuel oil consumption			
n = const ¹⁾ 100 %	g/kWh	177/178	177/178
85 %	g/kWh	176/177	176/177
75 %	g/kWh	178/178	178/178
50 %	g/kWh	185/185	185/185
Lubricating oil consumption ²⁾	g/kWh	0.6	0.6
NO _x emission ³⁾	g/kWh	10.0	10.0
Turbocharger type		2 x ABB A165	2 x ABB A170
Fuel			
Engine driven booster pump	m ³ /h	-/-	-/-
Stand-by booster pump	m ³ /h	8.4/5	11.2/5
Mesh size MDO fine filter	mm	0.025	0.025
Mesh size HFO automatic filter	mm	0.01	0.01
Mesh size HFO fine filter	mm	0.034	0.034
Nozzle cooling by lubricating oil system			
Lubricating Oil			
Engine driven pump	m ³ /h/bar	250/10	400/10
Independent pump	m ³ /h/bar	200/10	270/10
Working pressure on engine inlet	bar	4 - 5	4 - 5
Engine driven suction pump	m ³ /h/bar	-/-	-/-
Independent suction pump	m ³ /h/bar	350/3	470/3
Priming pump	m ³ /h/bar	30/5	40/5
Sump tank content/dry sump content	m ³	16.3	21.8
Temperature at engine inlet	°C	60 - 65	60 - 65
Temperature controller NB	mm	200	200
Double filter NB	mm	200	200
Mesh size double filter	mm	0.08	0.08
Mesh size automatic filter	mm	0.03	0.03

	Cylinder	12	16
Fresh water cooling			
Engine content	m ³	2.8	4
Pressure at engine inlet min/max	bar	4.5/6.0	4.5/6.0
Header tank capacity	m ³	1.5	2
Temperature at engine outlet	°C	80 - 90	80 - 90
Two circuit system			
Engine driven pump HT	m ³ /h/bar	200/4.7	350/4.7
Independent pump HT	m ³ /h/bar	200/3	350/3
HT-Controller NB	mm	200	200
Water demand LT-charge air cooler	m ³ /h	100	130
Temperature at LT-charge air cooler inlet	°C	38	38
Heat Dissipation			
Specific jacket water heat	kJ/kW	500	500
Specific lub oil heat	kJ/kW	525	525
Lub oil cooler	kW	1750	2335
Jacket water	kW	1667	2220
Charge air cooler (HT-Stage) ⁴⁾	kW	4940	6390
Charge air cooler (LT-Stage) ⁴⁾ (HT-Stage before engine)	kW	890	1365
Heat radiation engine	kW	511	680
Exhaust			
Silencer/spark arrester NB	mm	1200	1500
Pipe diameter after turbine	mm	2 x 900	2 x 1000
Exhaust gas mass flow (intake air 25 °C) ⁵⁾	kg/h	86520	107160
Exhaust gas temperature after turbine (intake air 25 °C) ⁵⁾	°C	312	310
Maximum exhaust gas back pressure	bar	0.03	0.03
Starting air			
Starting air pressure max.	bar	30	30
Minimum starting air pressure	bar	14	14
Air consumption per start ⁶⁾	Nm ³	3	3.5

- 1) Reference conditions: LCV = 42700 kJ/kg, ambient temperature 25 °C
charge air coolant temperature 25 °C, tolerance 5 %, + 1 % for engine driven pump
- 2) Standard value based on rated output, tolerance ± 0.3 g/kWh
- 3) MARPOL 73/78, annex VI, cycle E2, D2
- 4) Charge air heat based on 45 °C ambient temperature
- 5) Tolerance 10 %, rel. humidity 60 %
- 6) Preheated engine

VM 43 C – Low Emission Engine ► Heat Balance (Preliminary)

■ 12 M43C

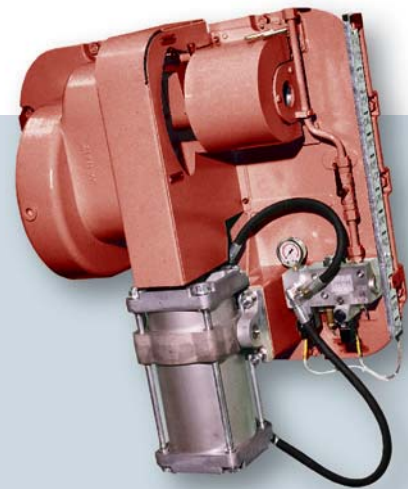
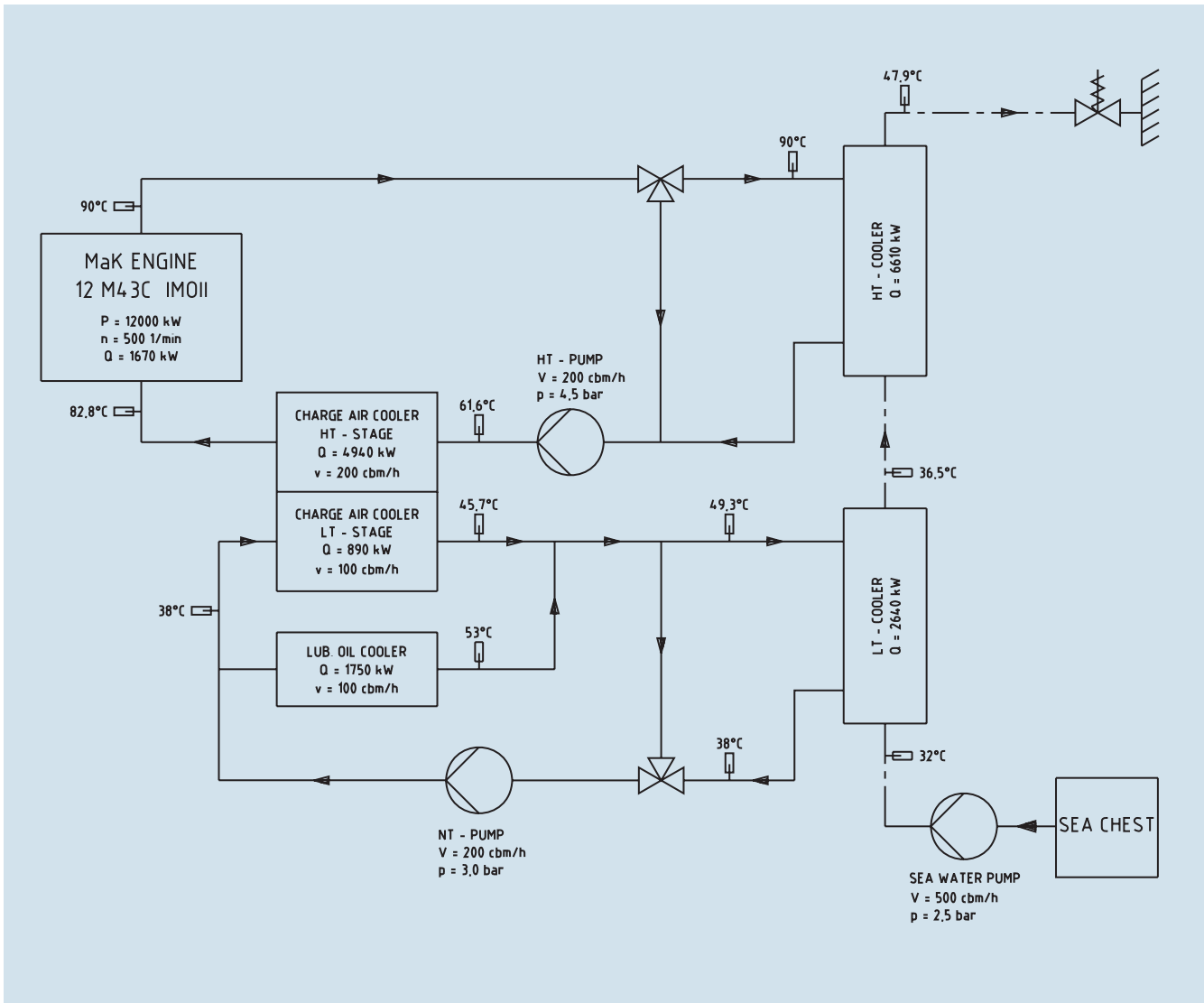

■ 16 M 43 C

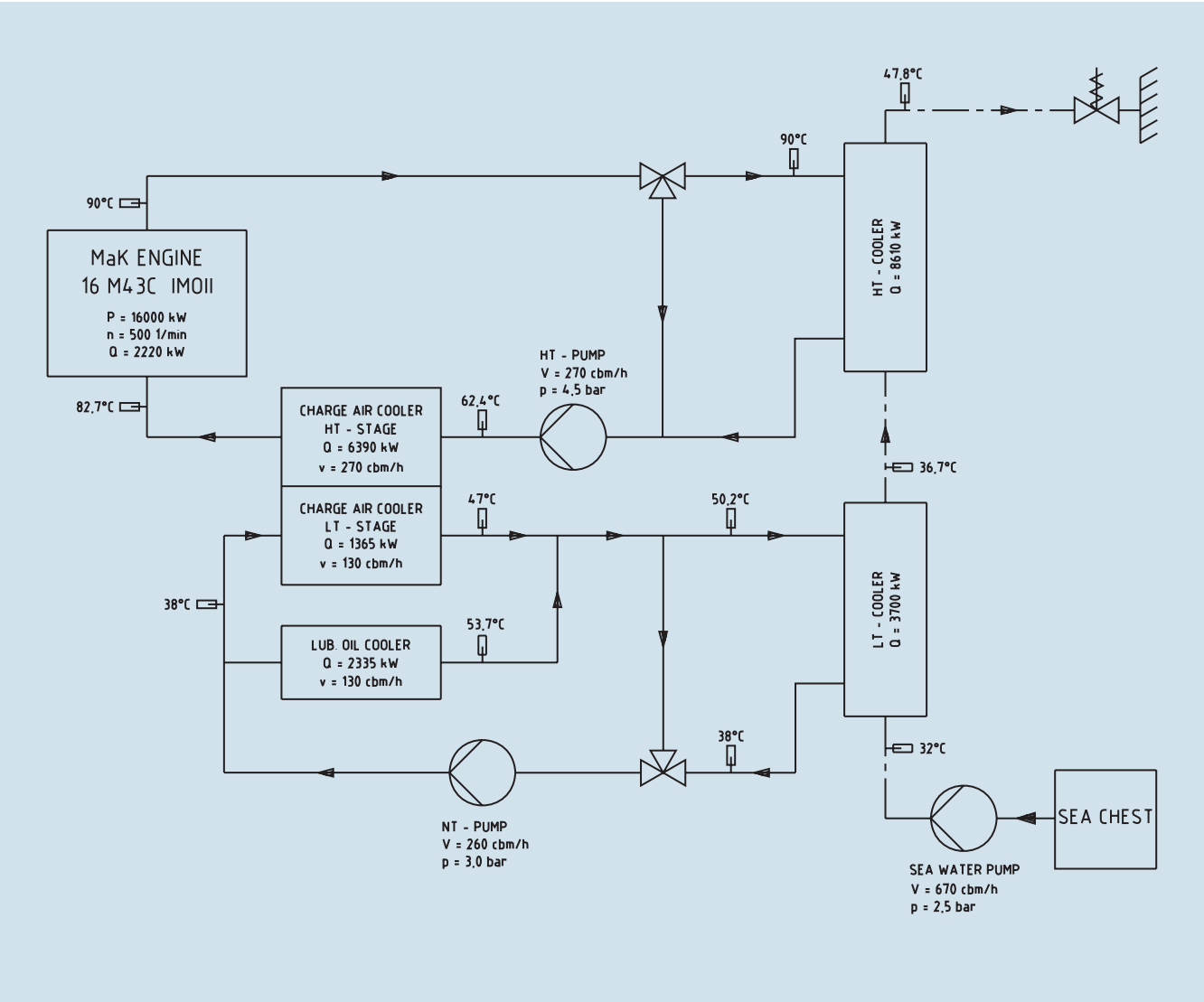

One Strong Line of World-Class Diesel Engines Perfect Solutions for Main Propulsion and On-Board Power Supply

The Program: Quality is our Motto

For more than 80 years we have developed, built, supplied and serviced diesel engines – worldwide. Today Caterpillar Marine with its brands Cat and MaK offer high-speed and medium-speed engines with power ratings from 11 kW to 16,000 kW. Many different engine families are available to meet your specific application needs.

Cat and MaK diesel engines are distinguished by high reliability, extremely low operational costs, simple installation and maintenance and compliance with IMO environmental regulations.

The application of engines in main and auxiliary marine power systems varies greatly and extends from high-speed boats and yachts, through tugs, trawlers and offshore vessels to freighters, ferries and cruise liners.

Caterpillar Marine Power Systems Sales and Service Organization

Caterpillar has combined the sales and service activities and responsibility of their Cat and MaK brand marine engine business into Caterpillar Marine Power Systems with headquarters in Hamburg/Germany.

In setting-up this worldwide structure, we have concentrated on integrating the Cat and MaK brand groups into a single, united marine team, which utilises the particular expertise of each group.

Commercial marine engine business is split into three geographic regions,
– Europe, Africa, Middle East
– Americas
– Asia-Pacific,



■ Medium-Speed Engines



● **M 20 C**
6, 8, 9 cylinder
1,020–1,710 kW

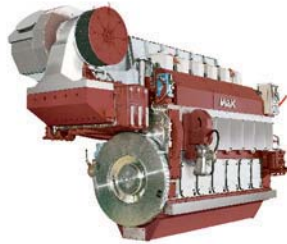

● **M 25 C**
6, 8, 9 cylinder
1,800–3,000 kW



● **M 32 C**
6, 8, 9 cylinder
2,880–4,500 kW

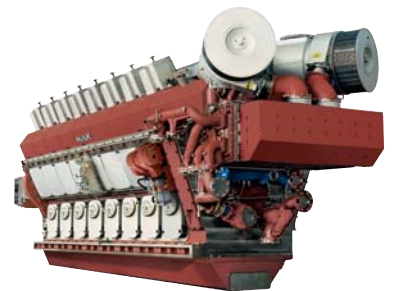

● **VM 32 C**
12, 16 cylinder
5,760–8,000 kW

10



Main Propulsion Engines

Caterpillar Marine Power Systems Production Facilities

which manage all sales and product support activities. They have direct responsibility for achieving the ambitious growth targets set for the Cat and MaK brands and for providing our customers and dealers with complete marine solutions.

Caterpillar's global dealer network provides a key competitive edge – customers deal with people they know and trust.

Cat dealers strive to form a strong working relationship with their customers, offering comprehensive and competent advice from project support to repair work.

Some of the most advanced manufacturing concepts are used at Caterpillar locations throughout the world to produce engines in which reliability, economy and performance are second-to-none.

From the production of core components to the assembly of complete engines, quality is always the top priority.

Comprehensive, recognized analysis systems, test procedures and measuring methods ensure that quality requirements are met throughout all the individual manufacturing phases. All of our production facilities are certified under 1:2000 ISO 9001 EN, the international benchmark that is helping to set new quality standards worldwide.

In addition to product quality, our customers expect comprehensive service which includes the supply of spare parts throughout the life of the engine.

Caterpillar Logistics Services, Inc., located in Morton, Illinois, is the largest parts distribution facility within the Cat Logistics network and is also the headquarters for all the worldwide distribution centres. Morton utilises sophisticated material handling, storage and retrieval systems to support Caterpillar's customer service goals.

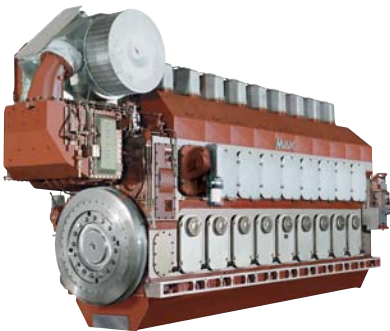

● **M 43 C**
6, 7, 8, 9 cylinder
5,400–9,000 kW

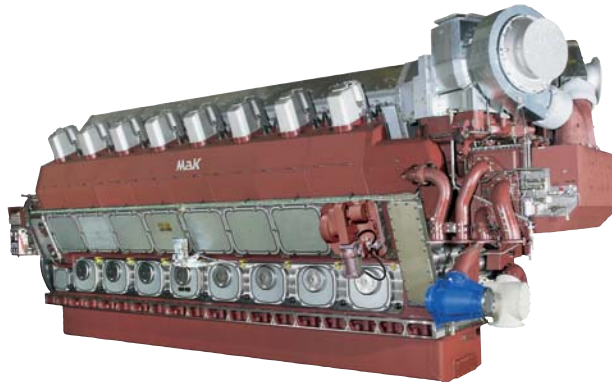

● **VM 43 C**
12, 16 cylinder
10,800–16,000 kW

▶ MaK LEE will soon be part of all MaK engines!

Caterpillar Marine Power Systems

Headquarters

Caterpillar Marine Power Systems
Neumühlen 9
22763 Hamburg/Germany

Phone: +49 40 2380-3000
Telefax: +49 40 2380-3535

Europe, Africa, Middle East

Caterpillar Marine Power Systems
Neumühlen 9
22763 Hamburg/Germany

Phone: +49 40 2380-3000
Telefax: +49 40 2380-3535

Americas

MaK Americas Inc.
3450 Executive Way
Miramar Park of Commerce
Miramar, FL 33025/USA
Phone: +1 954 885 3200
Telefax: +1 954 885 3131

Asia Pacific

Caterpillar Marine Trading (Shanghai) Co., Ltd.
25/F, Caterpillar Marine Center
1319, Yan'an West Road
200050 Shanghai/P. R. China
Phone: +86 21 6226 2200
Telefax: +86 21 6226 4500

Caterpillar Marine Asia Pacific Pte Ltd
14 Tractor Road
Singapore 627973/
Singapore
Phone: +65 68287-600
Telefax: +65 68287-624

**For more information please visit our website:
MARINE.CAT.COM**

Subject to change without notice.
Leaflet No. 249 · 09.09 · e · L+S · VM3

© 2009 Caterpillar All Rights Reserved. Printed in Germany. CAT, CATERPILLAR, their respective logos, ACERT, ADEM, „Caterpillar Yellow“ and the POWER EDGE trade dress, as well as corporate identity used herein, are trademarks of Caterpillar and may not be used without permission



Caterpillar Marine Power Systems is committed to sustainability. This document is printed on PEFC certificated paper.

