

M 20 C

Low Emission Engine

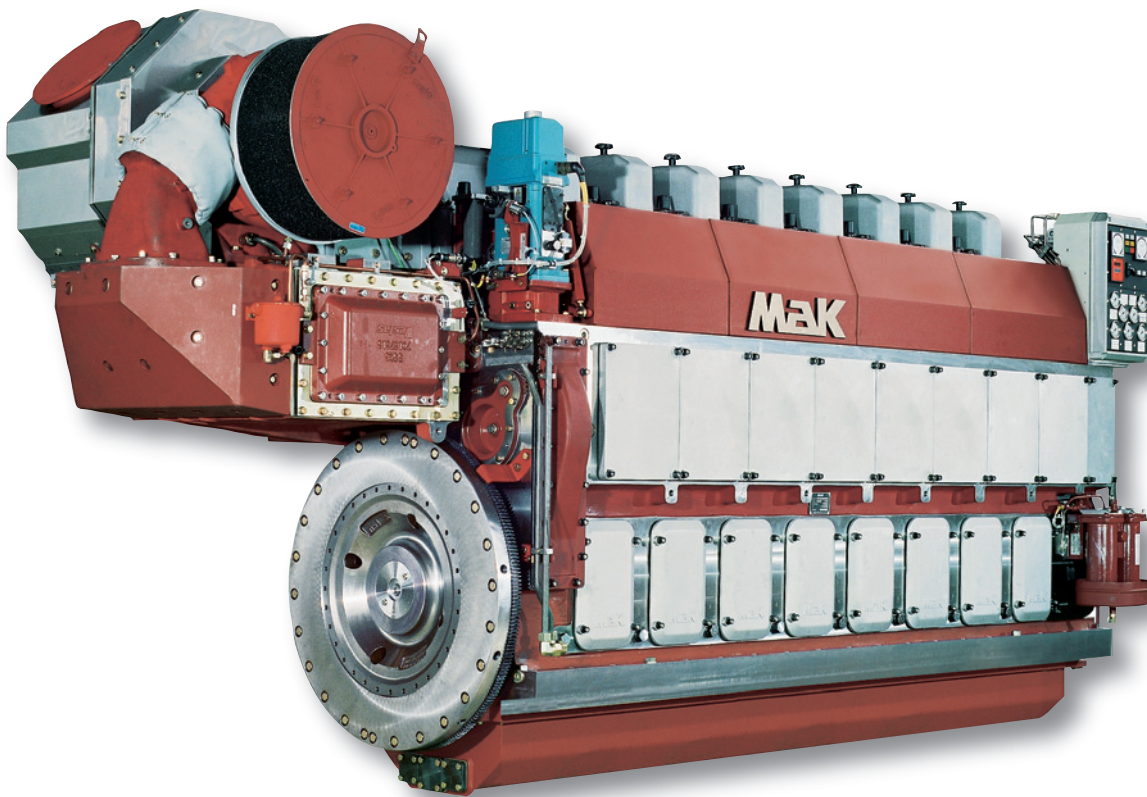

MAK

CATERPILLAR®

M 20 C ▶ Low Emission Engine

IMO II in sight – MaK Low Emission Engines already in operation

Back in 2000, Caterpillar Motoren identified three emission levels for the MaK marine product in order to cope with short to midterm emission regulations. These were a base line IMO engine, which fulfils MARPOL 73/78, Annex VI, an IMO-compliant engine and a Low Emission Engine (LEE) which meets the expected NO_x emission range of IMO II.

In addition, this strategy favours inside-the-engine means because of their clear advantage with respect to cost, complexity and maintenance.

■ A win-win situation for operators and the environment

All existing MaK M 20 C, M 25 C, M 32 C and M 43 C series marine engines afloat can be converted to MaK Low Emission Engines. Building upon proven technology residing inside the engine, MaK LEE bears many advantages for vessel owners and operators. MaK LEE today already provides a power plant complying with expected future IMO emission regulations. This allows shipping companies to increase their reputation for environmental-friendly marine business operations. In addition, the emission levels achieved with MaK LEE enable shipping companies to obtain so-called environmental classes with Marine Classification Societies, such as DNV Clean Design, GL Green Passport, LR Character N or the German Government's Blauer Engel. These environmental classes not only add to the vessel owner's image but also reduce harbour fees in some parts of the world.

■ As from 1. 1. 2011 IMO II will become effective

Already today Caterpillar is well prepared to meet these technological requirements. We are currently successfully testing engines that meet IMO II emission requirements.

The following components have been changed:

- injection system
- exhaust piping
- cylinder head

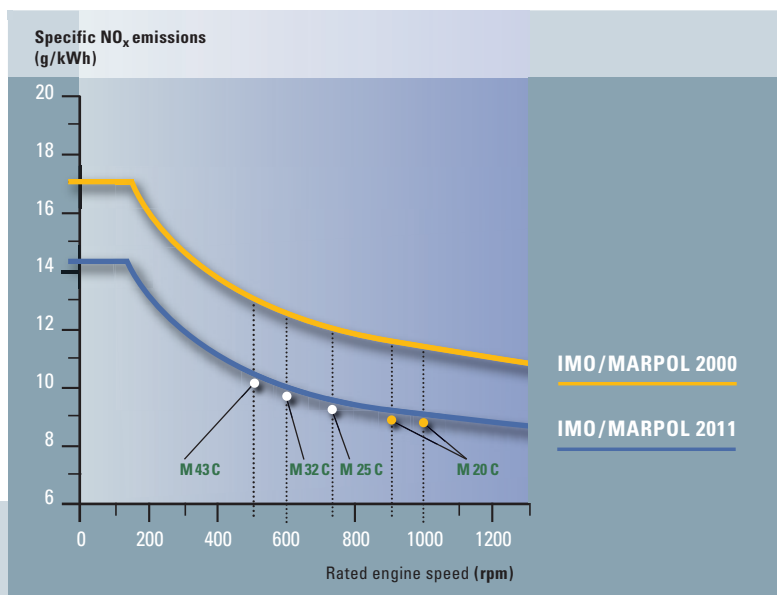

M 20 C – Low Emission Engine ▶ Engine Description (Preliminary)

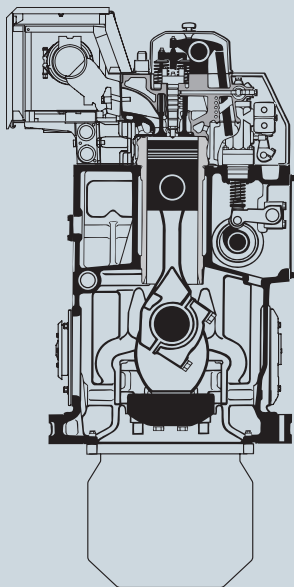

Number of cylinders	In-line	6, 8	6, 8
Bore	mm	200	200
Stroke	mm	300	300
Cylinder rating	kW	170	190
Speed	rpm	900	1000
Mean piston speed	m/s	9.0	10.0
BMEP	bar	24.1	24.2
Engine rating		kW	kW
	6 M 20 C	1020	1140
	8 M 20 C	1360	1520
Specific			
fuel consumption* at 100%/85% output	6, 8 M 20 C	g/kWh 186/186	g/kWh 190/189
Specific lubricating oil consumption		0.6 g/kWh, ± 0.3 g/kWh	
The engine fulfills MARPOL 73/78 Annex VI regulations.			

* LCV = 42,700 kJ/kg, without engine-driven pumps, tolerance 5%

Swept volume: 9.4 l/cyl. Turbocharging: single-pipe system
 Direction of rotation: clockwise, option: counter-clockwise

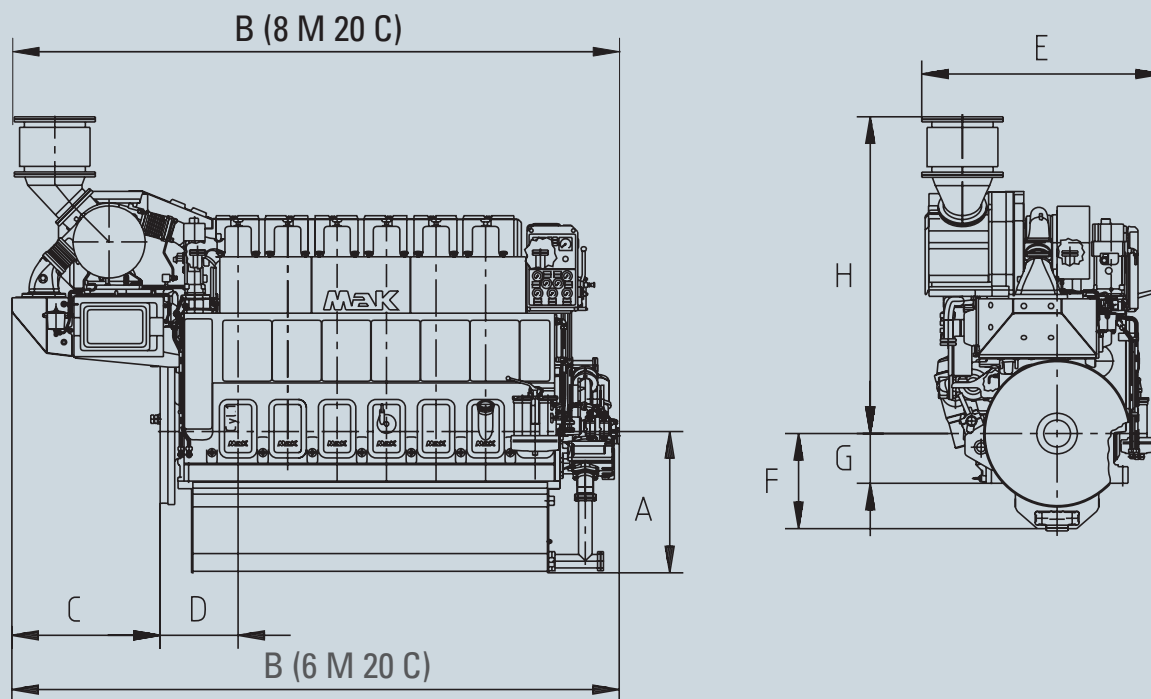

Dimensions (mm) and Weights (t)

Engine	A	B	C	D	E	F	G	H	t
6 M 20 C	941	4049	988	520	1596	630	330	2099	10.7
8 M 20 C	941	4846	988	520	1731	630	330	2236	14.0

A: Wet sump (standard) F: Dry sump (special request)

Engine centre distance: 2010 mm

Removal of cylinder liner:
 in transverse direction 1910 mm
 in longitudinal direction 2085 mm

Nozzle position: ask for availability

Engine with turbocharger at free end available,
 ask for dimensions

M 20 C – Low Emission Engine Technical Data (Preliminary)

	Cylinder	6		8	
Performance data					
Maximum continuous rating acc. ISO 3046/1	kW	1020	1140	1360	1520
Speed	1/min	900	1000	900	1000
Minimum speed	1/min	280	300	280	300
Brake mean effective pressure	bar	24.1	24.2	24.1	24.2
Charge air pressure	bar	3.3	3.4	3.3	3.4
Firing pressure	bar	185	185	185	185
Combustion air demand (ta = 20 °C)	m³/h	6535	7300	8700	9740
Specific fuel oil consumption					
propeller/n = const ¹⁾ 100 %	g/kWh	186	190	186	190
85 %	g/kWh	186/186	189/189	186/186	189/189
75 %	g/kWh	188/189	189/189	188/189	189/189
50 %	g/kWh	195/199	191/195	195/199	191/195
Lubricating oil consumption ²⁾	g/kWh	0.6	0.6	0.6	0.6
NO _x emission ³⁾	g/kWh	8.5	8.5	8.5	8.5
Turbocharger type		HPR 4000	HPR 4000	HPR 5000	HPR 5000
Fuel					
Engine driven booster pump	m³/h/bar	1.2/5	1.2/5	1.2/5	1.2/5
Stand-by booster pump	m³/h/bar	0.8/10	0.8/10	1.0/10	1.0/10
Mesh size MDO fine filter	mm	0.025	0.025	0.025	0.025
Mesh size HFO automatic filter	mm	0.010	0.010	0.010	0.010
Mesh size HFO fine filter	mm	0.034	0.034	0.034	0.034
Nozzle cooling by lubricating oil system					
Lubricating Oil					
Engine driven pump	m³/h/bar	52.5/10	58.8/10	52.5/10	58.8/10
Independent pump	m³/h/bar	35/10	35/10	45/10	45/10
Working pressure on engine inlet	bar	4 - 5	4 - 5	4 - 5	4 - 5
Engine driven suction pump	m³/h/bar	-	-	-	-
Independent suction pump	m³/h/bar	-	-	-	-
Priming pump pressure/suck pump	m³/h/bar	5/5/8/3	5/5/8/3	8/5/10/3	8/5/10/3
Sump tank content/dry sump content	m³	1.7/0.5	1.7/0.5	2.3/0.5	2.3/0.5
Temperature at engine inlet	°C	55 - 65	55 - 65	55 - 65	55 - 65
Temperature controller NB	mm	-	-	-	-
Double filter NB	mm	65/65	65/65	65/65	65/65
Mesh size double filter	mm	-	-	-	-
Mesh size automatic filter	mm	0.03	0.03	0.03	0.03

	Cylinder	6		8	
Fresh water cooling					
Engine content	m ³	0.12	0.12	0.16	0.16
Pressure at engine inlet min/max	bar	2.5/6.0	2.5/6.0	2.5/6.0	2.5/6.0
Header tank capacity	m ³	0.1	0.1	0.1	0.1
Temperature at engine outlet	°C	80 - 90	80 - 90	80 - 90	80 - 90
Two circuit system					
Engine driven pump HT	m ³ /h/bar	25/3.4	30/4.2	30/3.4	35/4.2
HT-Controller NB	mm	50	50	65	65
Engine driven pump LT	m ³ /h/bar	40/3.2	45/4.0	40/3.2	45/4.0
Temperature at oil cooler inlet (max.)	°C	38	38	38	38
Heat Dissipation					
Specific jacket water heat	kJ/kW	550	550	550	550
Specific lub oil heat	kJ/kW	500	500	500	500
Lub oil cooler	kW	142	158	208	232
Jacket water	kW	156	174	189	211
Charge air cooler ⁴⁾	kW	433	499	577	665
Heat radiation engine	kW	52	52	69	69
Exhaust gas					
Silencer/spark arrester NB 25 dBA	mm	400/400	400/400	500/500	500/500
Pipe diameter NB after turbine	mm	400	400	500	500
Maximum exhaust gas pressure drop	bar	0.03	0.03	0.03	0.03
Exhaust gas temperature after turbine (intake air 25°C) ⁵⁾	°C	360	360	350	330
Exhaust gas mass flow (intake air 25°C) ⁵⁾	kg/h	8080	9025	10750	12050
Starting air					
Starting air pressure max.	bar	30	30	30	30
Minimum starting air pressure	bar	7	7	7	7
Air consumption per start ⁶⁾	Nm ³	0.5	0.5	0.5	0.5

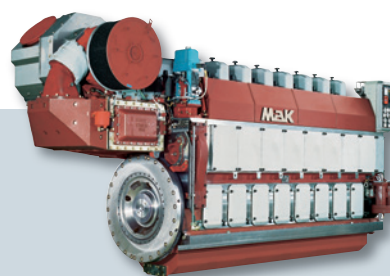

- 1) Reference conditions: LCV = 42700 kJ/kg, ambient temperature 25 °C
charge air coolant temperature 25 °C, tolerance 5 %, + 1 % for engine driven pump
- 2) Standard value based on rated output, tolerance ± 0.3 g/kWh
- 3) MARPOL 73/78, annex VI, cycle E2, E3, D2
- 4) Charge air heat based on 45 °C ambient temperature
- 5) Tolerance 10 %, rel. humidity 60 %
- 6) Preheated engine

M20 C – Low Emission Engine ► Heat Balance (Preliminary)

■ 6 M20C

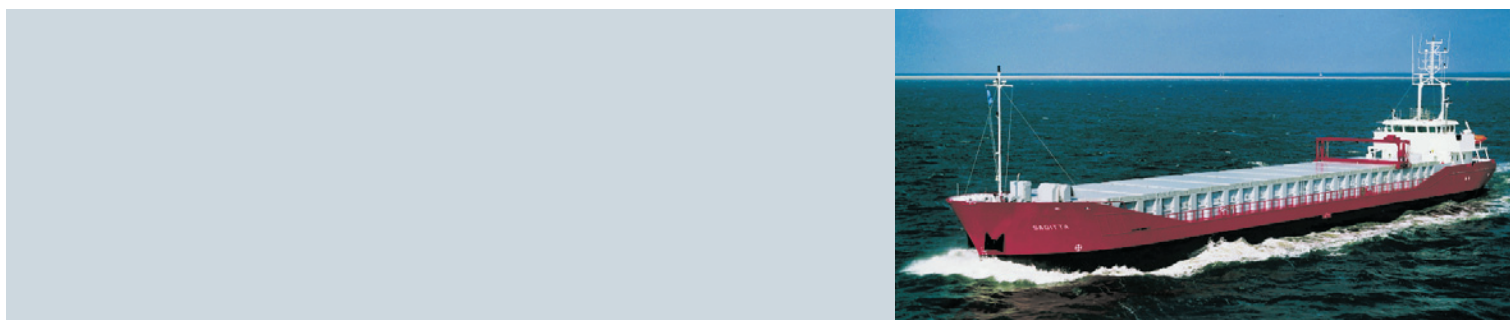
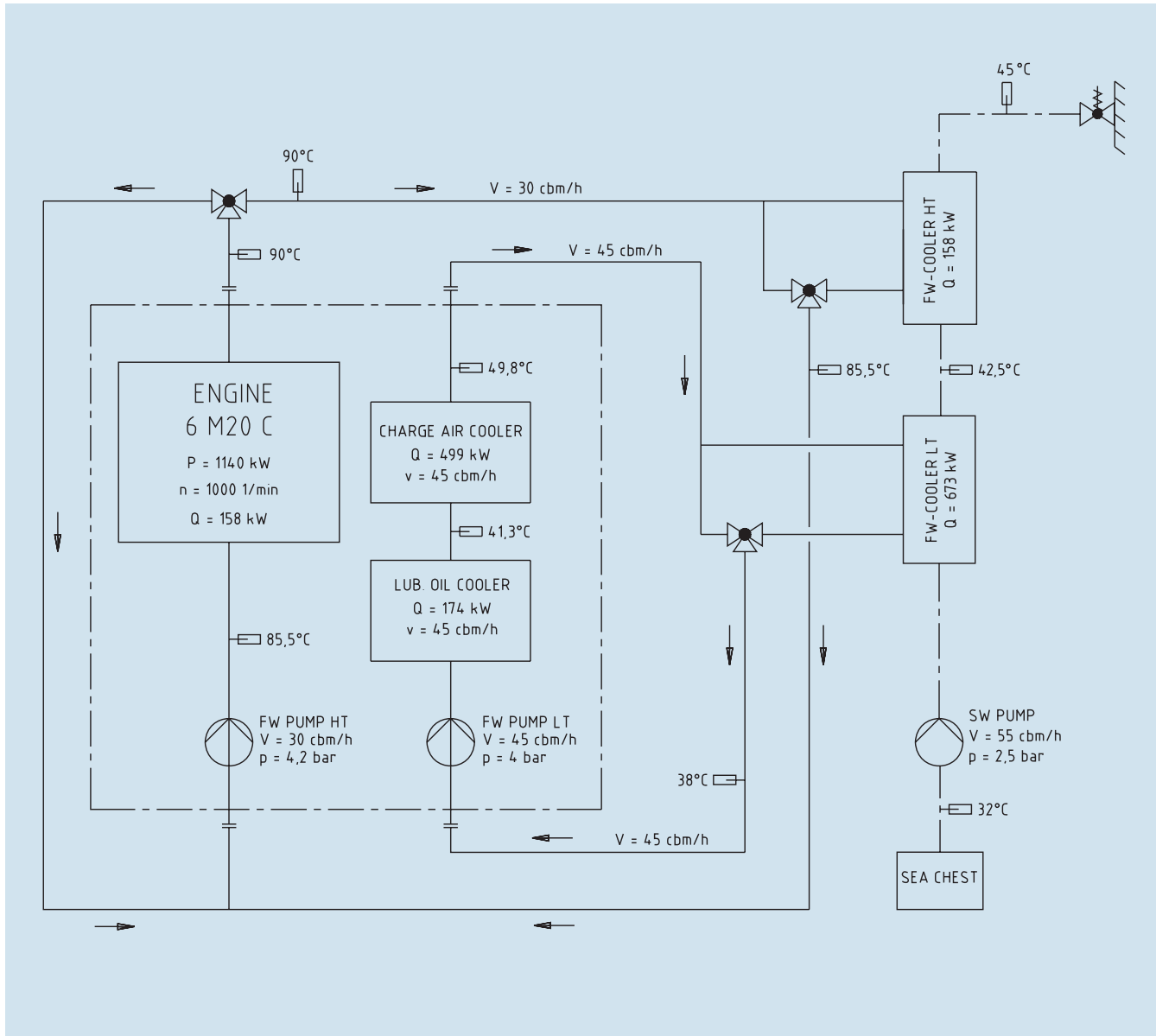

■ 8 M20C

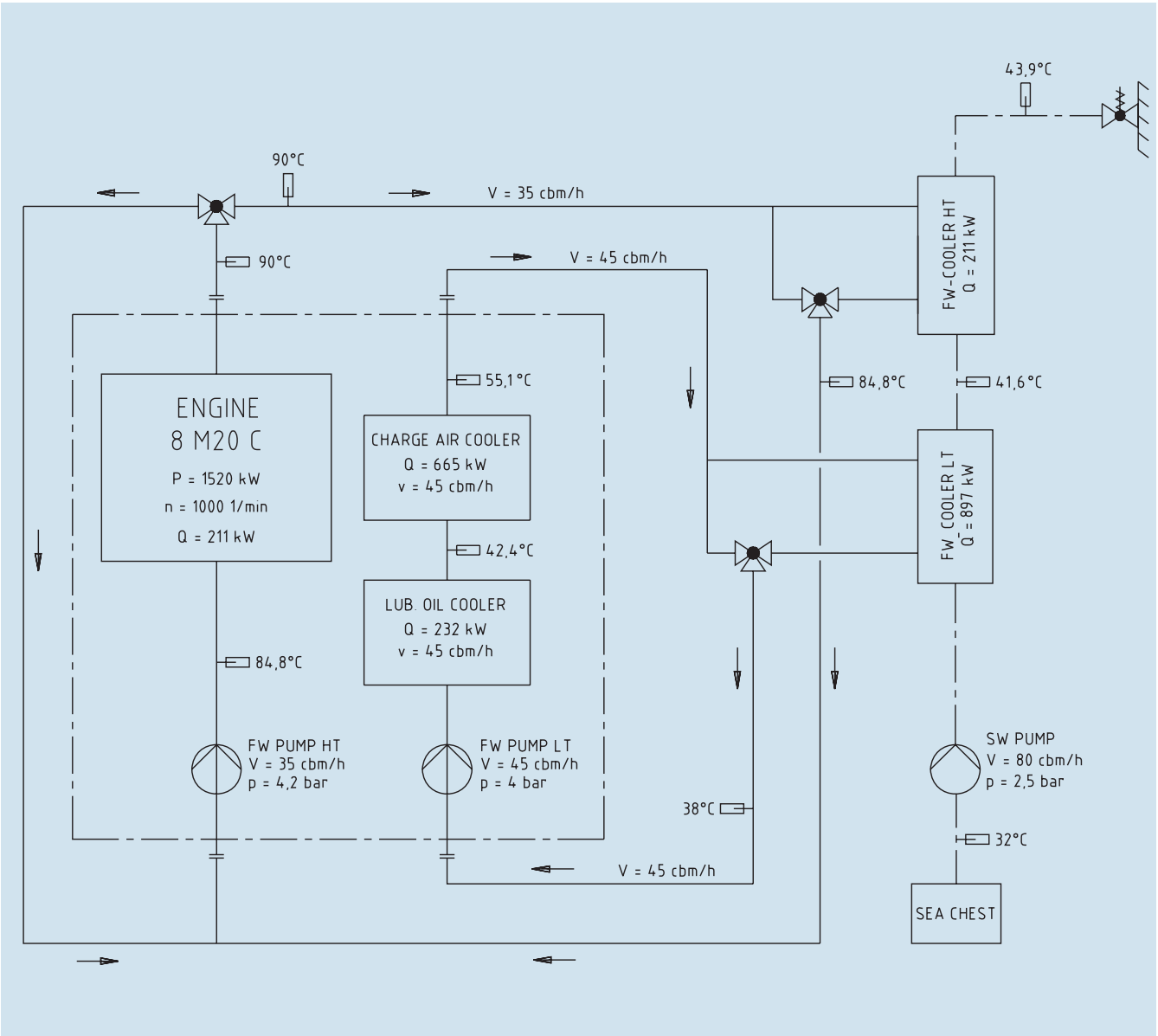

Caterpillar Marine Power Systems

Headquarters

**Caterpillar Marine
Power Systems**
Neumühlen 9
22763 Hamburg/Germany

Phone: +49 40 2380-3000
Telefax: +49 40 2380-3535

Europe, Africa, Middle East

**Caterpillar Marine
Power Systems**
Neumühlen 9
22763 Hamburg/Germany

Phone: +49 40 2380-3000
Telefax: +49 40 2380-3535

Americas

MaK Americas Inc.
3450 Executive Way
Miramar Park of Commerce
Miramar, FL 33025/USA
Phone: +1 954 885 3200
Telefax: +1 954 885 3131

Asia Pacific

**Caterpillar Marine Trading
(Shanghai) Co., Ltd.**
25/F, Caterpillar Marine Center
1319, Yan'an West Road
200050 Shanghai/P. R. China
Phone: +86 21 6226 2200
Telefax: +86 21 6226 4500

**Caterpillar Marine Asia
Pacific Pte Ltd**
14 Tractor Road
Singapore 627973/
Singapore
Phone: +65 68287-600
Telefax: +65 68287-624

**For more information please visit our website:
MARINE.CAT.COM**

Subject to change without notice.
Leaflet No. 254 · 10.09 · e · LWK · VM3

© 2009 Caterpillar All Rights Reserved. Printed in Germany. CAT, CATERPILLAR, their respective logos, ACERT, ADEM, „Caterpillar Yellow“ and the POWER EDGE trade dress, as well as corporate identity used herein, are trademarks of Caterpillar and may not be used without permission



Caterpillar Marine Power Systems is committed to sustainability. This document is printed on PEFC certificated paper.

